

5M PTZ Dome Network Camera

x33



Feature

- 5MP (2592 X 1944)H.265+/H.264+/MJPEG
- Max. resolution: 2592 X 1944
- Full Color / Active Deterrence Camera
- 4.3 ~ 142mm Motorized Lens (F1.6)
- 3D DNR, WDR, HLC, BLC, ROI encoding
- Intelligent Analytics
- Built-in micro SD card slot, up to 256GB
- IP66 ingress protection
- DC12V/PoE power supply

Dimension

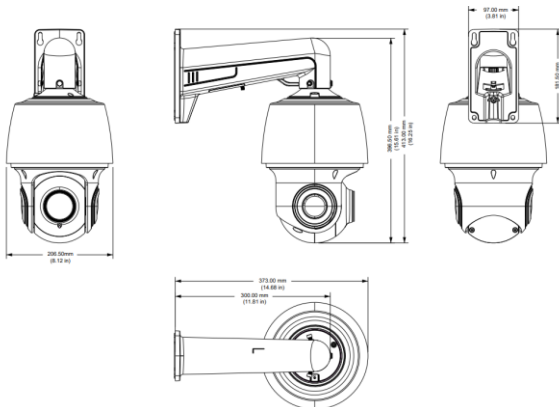

VVK-NSZ51X33

Specification

CAMERA

Image Sensor	1/2.7" Progressive Scan CMOS
Image Size	2592x1944
Shutter Speed	1/5s to 1/20000s
Min. Illumination	Color: 0.003 Lux @ (F1.6, AGC ON), B/W:0 Lux with IR
IR Distance	150M
Lens	4.3mm to 142mm @ F No. 1.6 H: 55(W) - 2.3(T)° V: 41.6(W) - 1.7(T)° D : 67.9(W) - 2.8(T)°

PTZ

Pan Range	360°
Pan Speed	Configurable from 0.6° to 200°/s; preset speed: 200°/s
Tilt Range	-10° to 90° (auto flip)
Tilt Speed	Configurable from 0.6° to 90°/s, preset speed 100°/s
Optical Zoom	33x

VIDEO IMAGE

Video Compression	H.265+/H.265/H.264+/H.264/MJPEG
Resolution	5MP(2592x1944) 4MP(2592x1520), 3MP(2048x1536 / 2304x1296), 1080P(1920x1080), 20P(1280x720), VGA(640x480),QVGA(320x240) @50/60 Hz 60Hz: 5MP(2592x1944) @ 20FPS / 4MP(2560x1440), 3MP(2048x1536 / 2304x1296), 1080P(1920x1080), 720P(1280x720) @ 30 FPS 50Hz:
Main Stream	5MP(2592x1944) @ 20FPS / 4MP(2560x1440), 3MP(2048x1536 / 2304x1296), 1080P(1920x1080), 720P(1280x720) @ 25 FPS
Video Bit Rate	256Kbps ~ 8Mbps

NETWORK / INTERFACE

Network	RJ45(10/100BASE-T)
Network Protocol	TCP/IP,HTTP,DHCP,DNS,DDNS,RTP/RTSP,SMTP,NTP,UPnP,SNMP,HTTPS,FTP
Interface Protocol	ONVIF(Profile S/G/T)

FUNCTIONS

Remote Monitoring	Avycon CMSONE, Avycon Mobile One
Smart Alarm	Motion detection Face Recognition (FR) Human&Vehicle Detection (PD &VD) Perimeter Intrusion Detection (PID) Line Crossing Detection (LCD)
Smart Analytics	Cross Counting (CC) Stationary Object Detection (SOD) Heat Map (HM) Crowd Density Detection (CD) Queue Length Detection (QD) license Plate Detection (LPD) Rare Sound Detection (RSD)

GENERAL

Power Supply	DC 12V/POE+, max. 25.6W
Power Consumption	N/A
Operating Environment	-30 °C to 60 °C
Dimensions	Ø206.4mm X 413.0 mm
Weight	3.7kg
Ingress Protection	IP66